

CHAIN CONVEYOR SYSTEMS

The reliable and economic transport solution for production and assembly processes

- Transport system for highly flexible interlinking of different production areas
- Based on a sturdy, modular design
- Designed to interlink, buffer and safeguard technologically necessary processes over a wide range of part sizes and weights

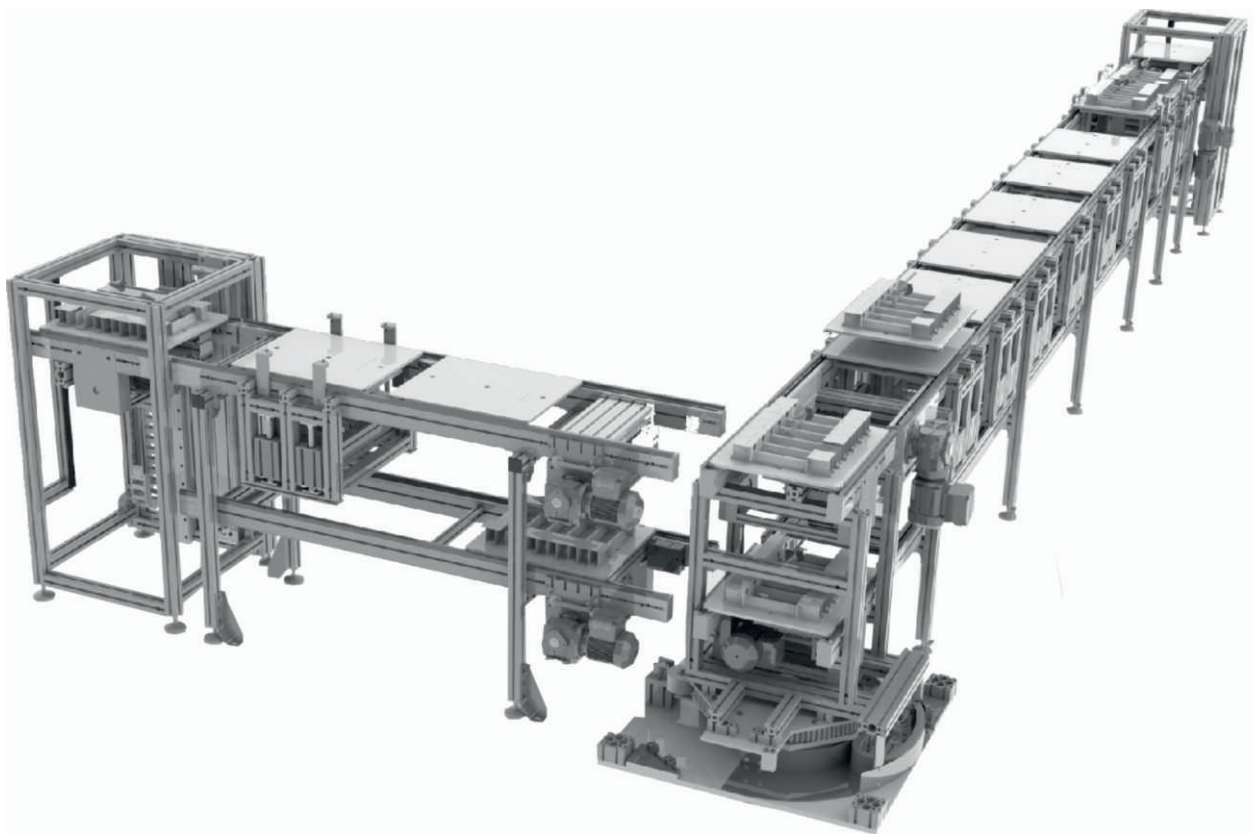

Flexible

Our ALTRATEC chain conveyor systems are based on Standardized Mechanical Modules.

These can also be combined with other ALTRATEC conveyor systems to create customized transport solutions.

Cost-effective

Since many modules are used across the entire spectrum of the ALTRATEC conveyor systems, we are able to offer appropriate and affordable solutions for every application.

Durable

The proven designs of ALTRATEC conveyor systems have been developed for use in a wide variety of industrial environments and have proven their durability in many applications.

Low-maintenance

All conveyors can be equipped with automatic chain tensioning and lubrication systems.

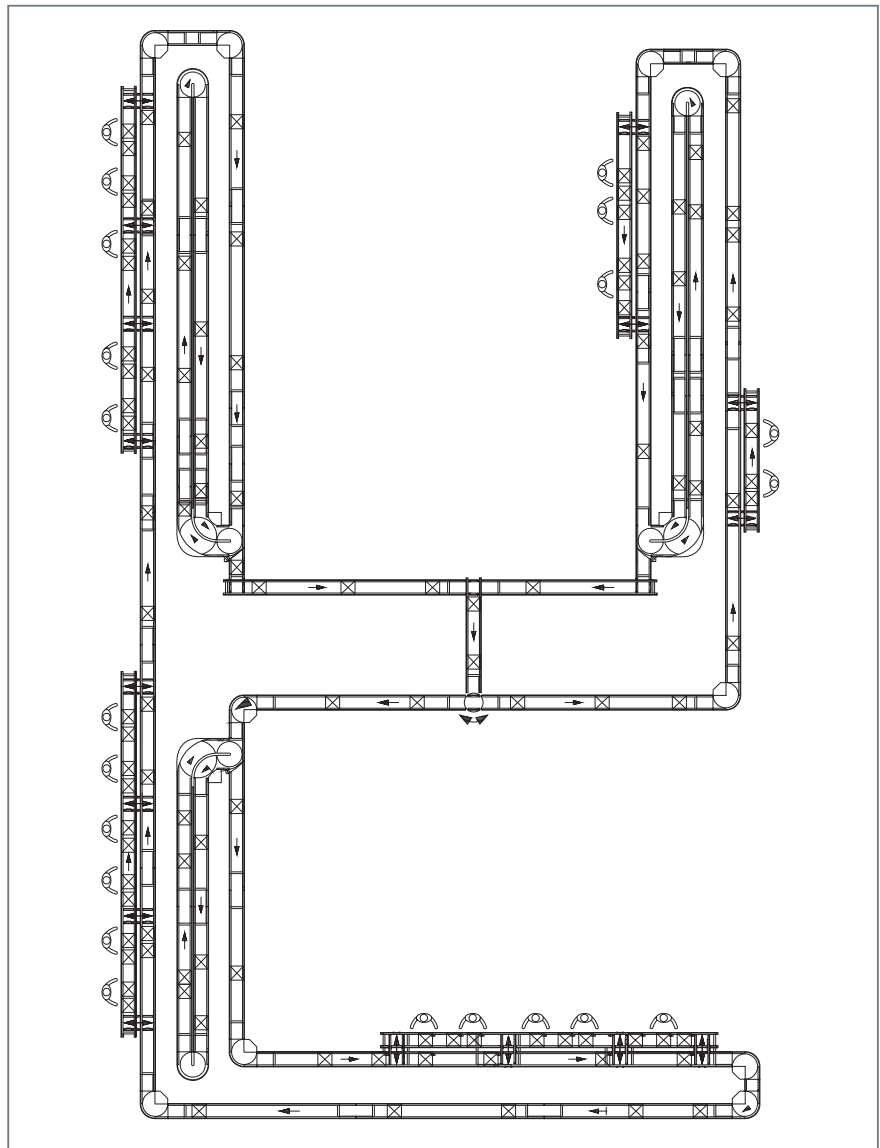

Modular structure

Conveyors of different designs allow for an exact adaptation to the respective transport requirements and circumstances.

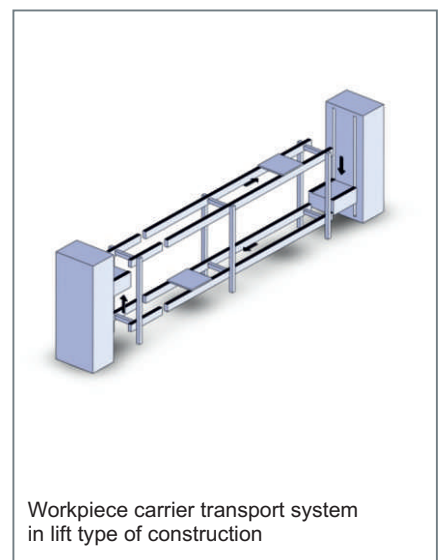
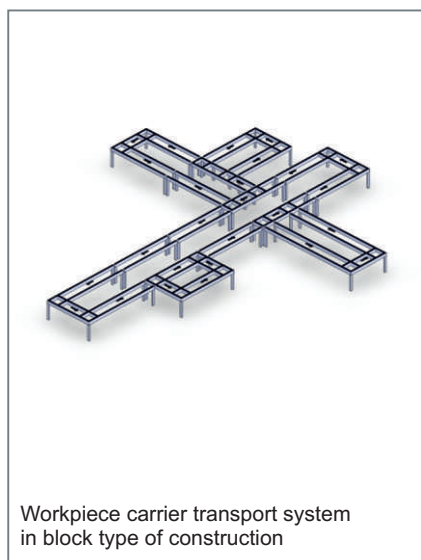

Transport media:	Accumulating roller chains made of steel, stainless steel or plastic (also available in curve-flexible design) Deep link conveyor chains made of steel with case-hardened plate links
Conveying speeds:	up to max. 20 m/min
Workpiece carrier dimensions:	180 x 180 ... 2 000 x 2 000 mm (other sizes available on request)
Workpiece carrier weight incl. workpiece:	up to max. 400 kg
Positioning accuracy of workpiece carrier:	+/- 0.15 mm
Workpiece carrier switchover times:	> 3 sec (depending on workpiece carrier dimension & weight)

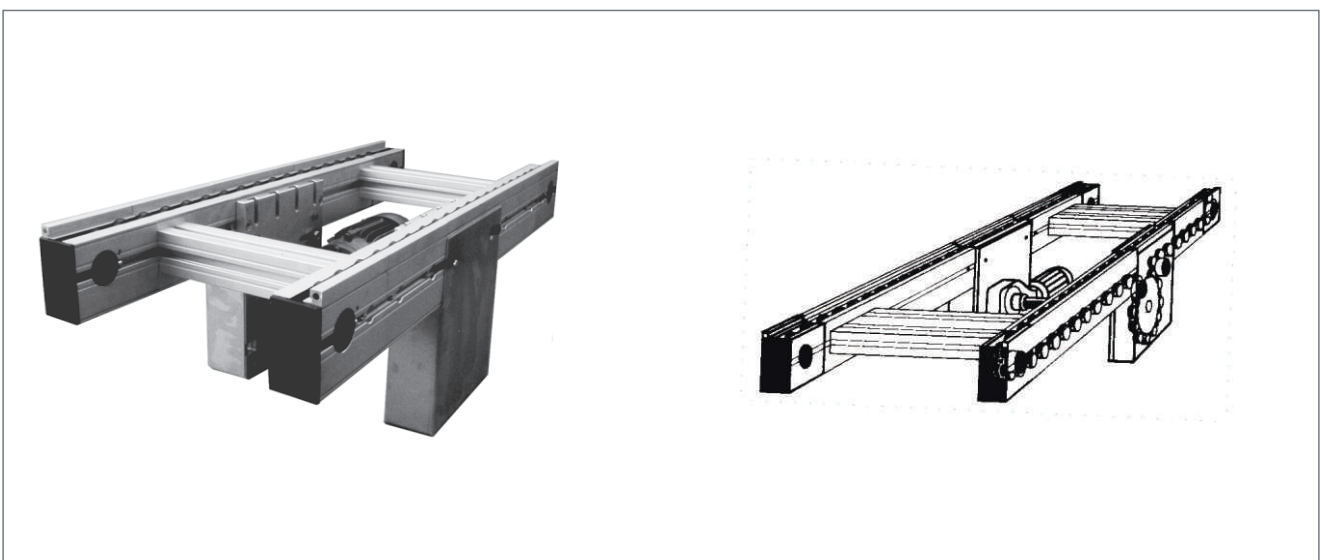
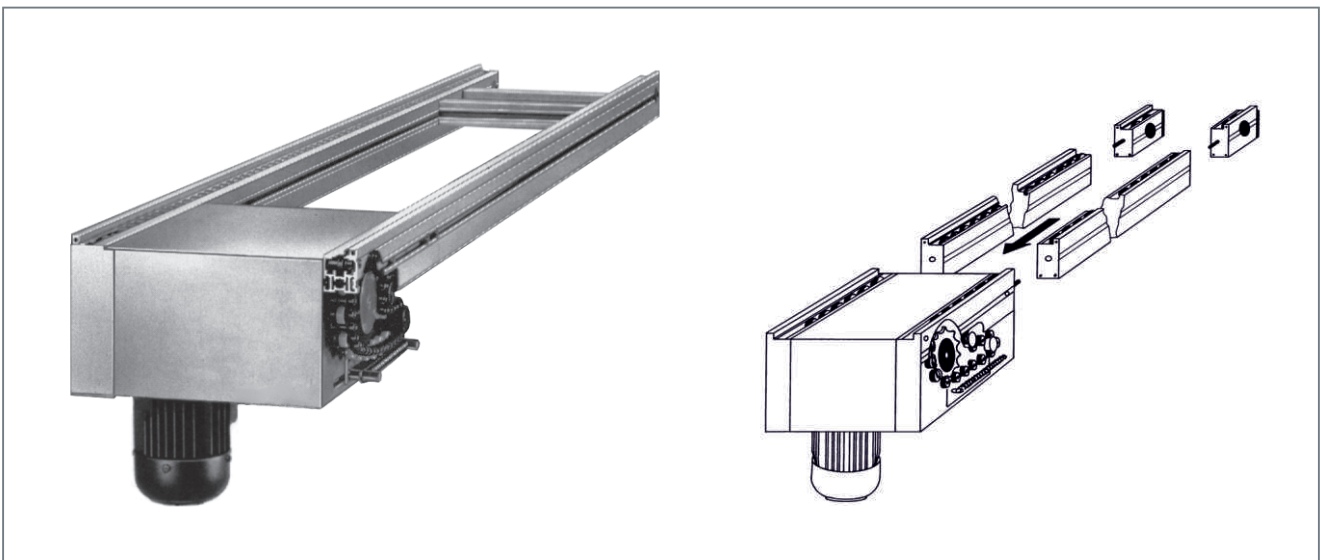

The ALTRATEC transfer profile

The ALTRATEC transfer profile forms a basis both for chain conveyors and for belt conveyors and accommodates the running surfaces for different transport means. It serves as a base element for setting up ALTRATEC transfer systems and is thus integrated with its slot system in the ALTRATEC aluminum profile program.

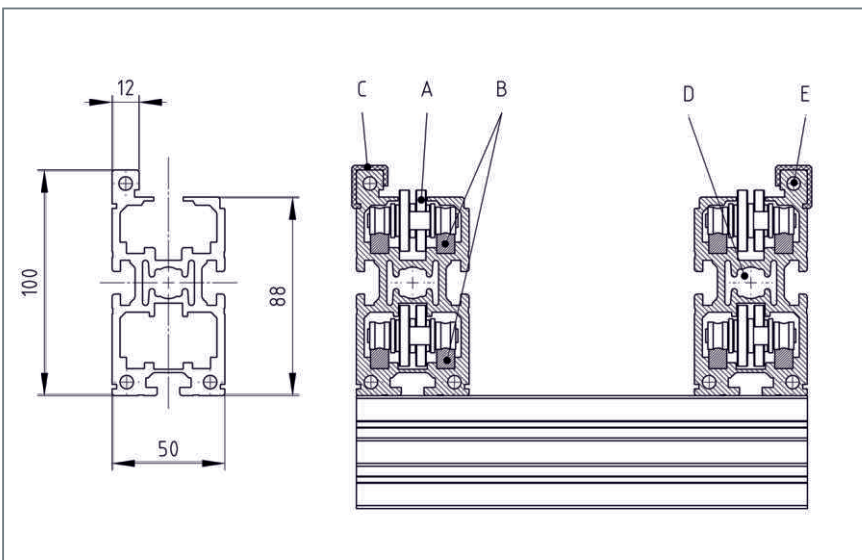
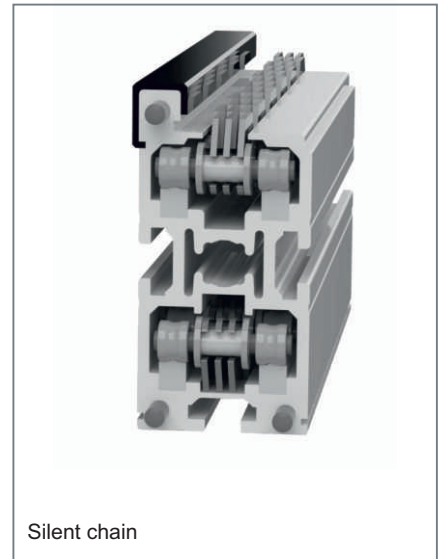
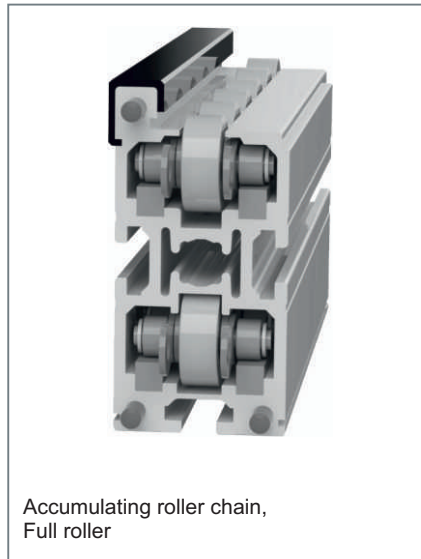
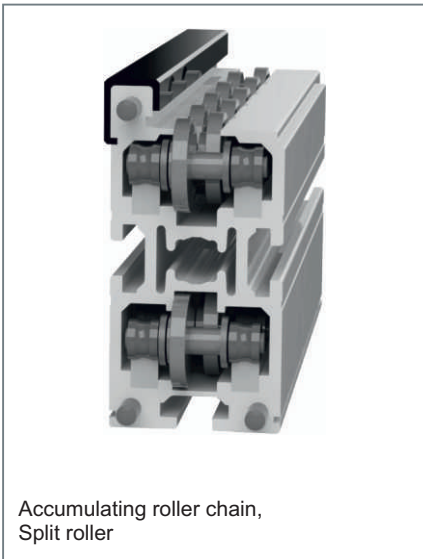
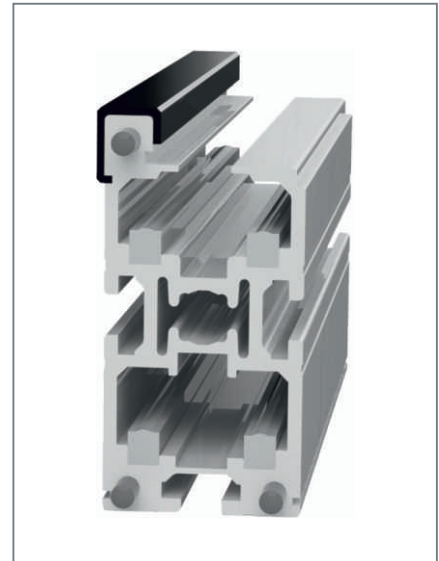

Cross section of an ALTRATEC chain conveyor

- A Accumulating roller chain
- B Chain support
- C WC guide rail
- D Central bore for section connectors
- E Fixing pins

The drives

ALTRATEC chain conveyor systems are operated by energy-efficient and low-noise three-phase geared motors.

The maintenance-free drive units of modular design ensure an optimum and low-loss transfer of driving power to the conveyor chains.

The integrated tension units constantly ensure a correct tension of chain throughout the entire service life of the conveyor chains.

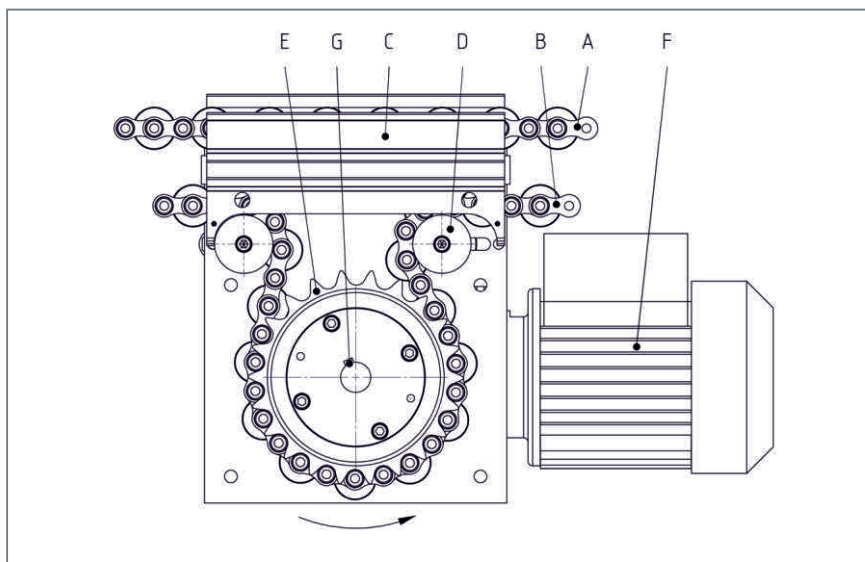
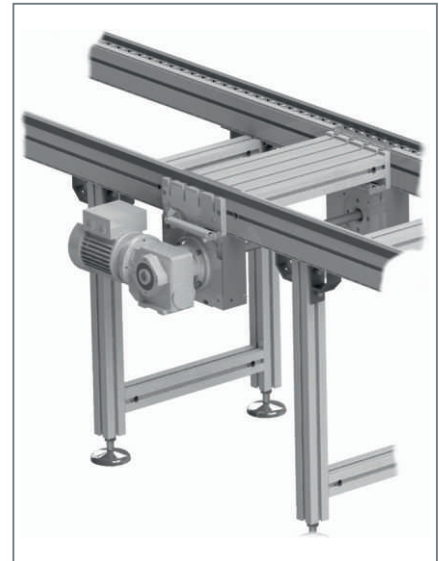

Drive half of an accumulating roller chain conveyor (Figure without cladding)

- A Accumulating roller chain tight span
- B Accumulating roller chain slack span
- C Transfer profile
- D Tension pulley
- E Chain drive sprocket
- F Drive motor
- G Consistent stub shafts

The supports

The support systems consisting of ALTRATEC aluminum profiles are characterized by ruggedness and great variability. They ensure a millimeter-precise and permanent alignment of our ALTRATEC conveyor systems.

Adjustable feet with steel or plastic disks can be adapted to all given floor conditions and are used for adjusting the conveyor systems.

Foundation mounting brackets guarantee stability during operation.

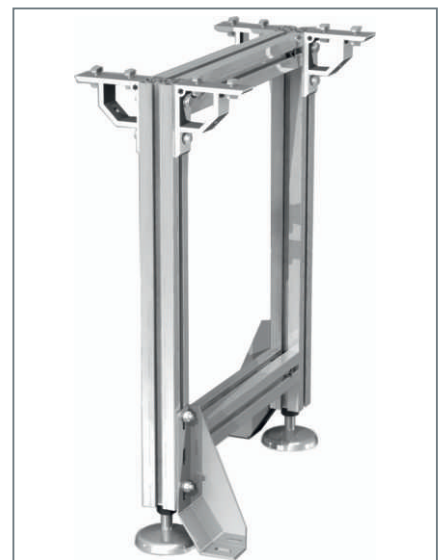

Sample systems

The combination with other ALTRATEC conveyors, e.g. double belt chain conveyors, plate reversals and guides, lift/transverse units, rotary units, etc. results in complex conveyor systems.

If necessary, drip trays can also be integrated in the ALTRATEC profile support frames.

All danger zones existing between moving parts are safely covered at manual workstations.

The ALTRATEC conveyor systems can easily be extended at any time by adding workstation equipment based on consistent use of ALTRATEC aluminum profiles with a wide variety of existing profile accessories.

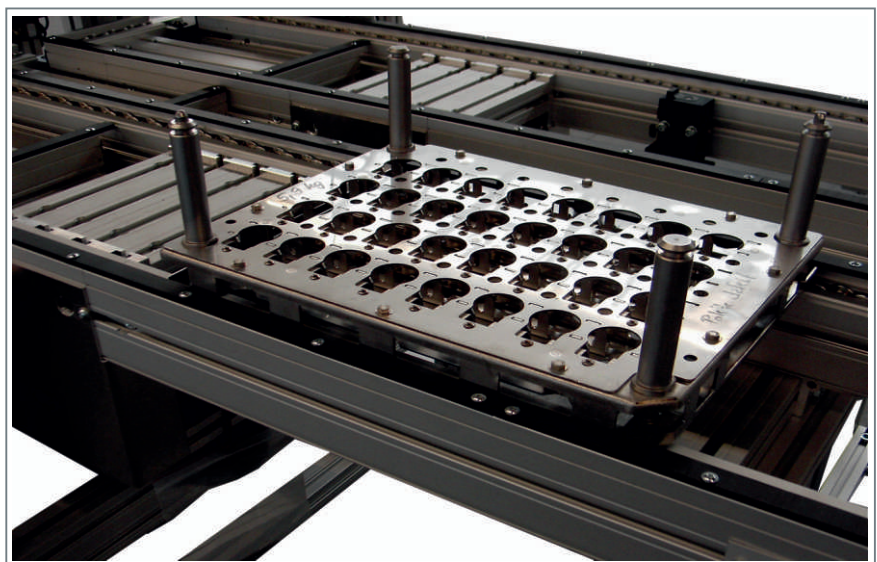
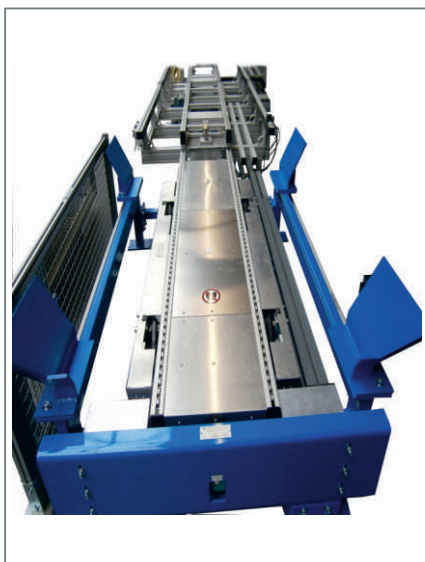
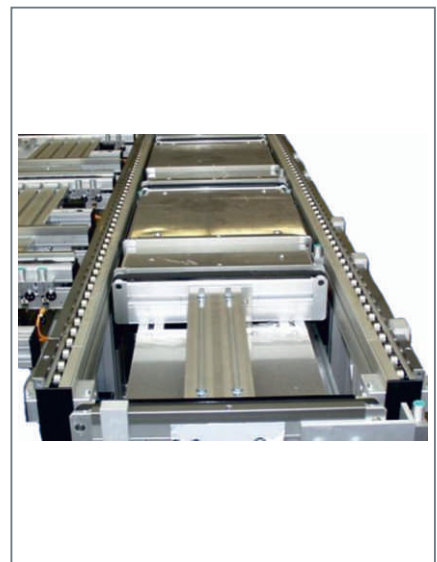
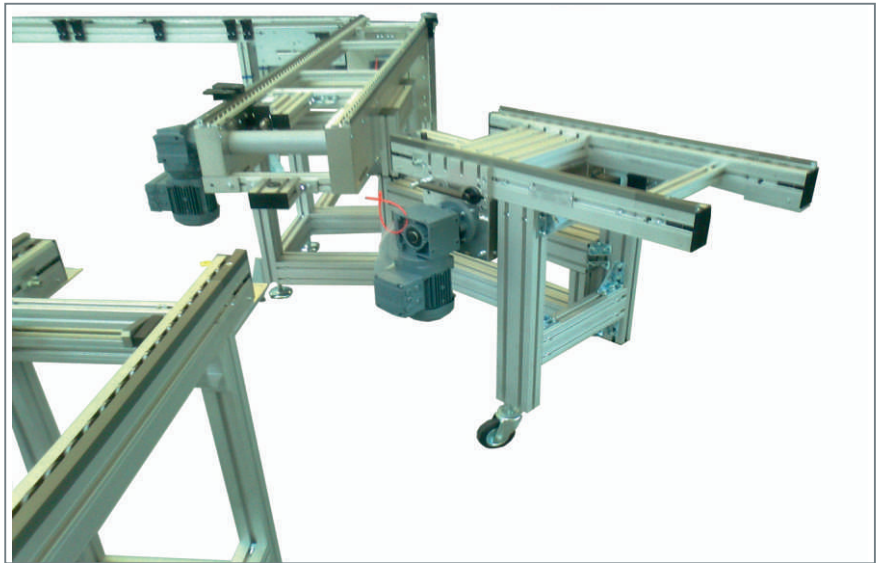

Sample systems

ALTRATEC chain conveyors can be adapted to a large number of workpiece carriers.

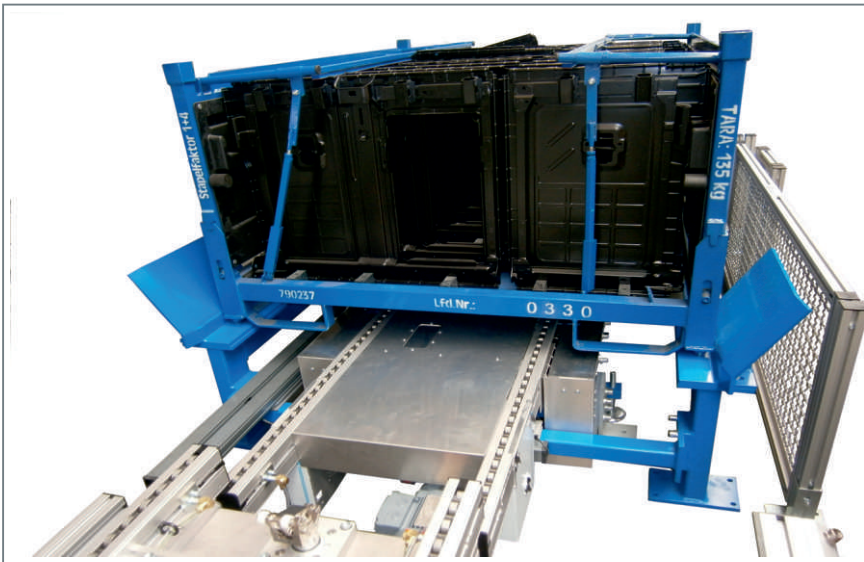

ALTRATEC chain conveyors can also be equipped with side-bow chains. All conceivable topologies are possible thanks to the combination with plate reversals, lift/transverse units, lift-type units, etc.

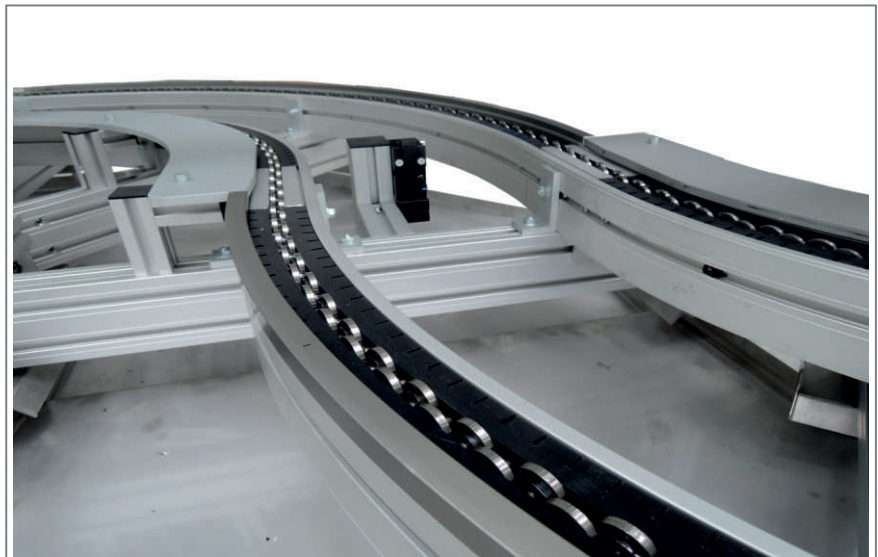

ALTRATEC Automation GmbH

Stuttgart Plant
Am Längenbühl 1
71229 Leonberg
GERMANY
Ph. +49 7152 3 56 56-0
Fax. +49 7152 3 56 56-29
www.altratec.de · info@altratec.de

Certified according to DIN EN ISO 9001

ALTRATEC Automation GmbH

Chemnitz Plant
Südstraße 9
09221 Neukirchen
GERMANY
Ph. +49 371 28134-0
Fax. +49 371 28134-34
www.altratec.de · info@altratec.de

China Plant

Bachtel Ltd.
Suzhou New District, Suzhou City,
Jiangsu Province
China, P.C. 215151
Ph. +86 512 65 36 00 65
Fax. +86 512 65 36 09 06